

**DE** MONTAGEANLEITUNG  
**EN** MOUNTING INSTRUCTIONS  
**FR** INSTRUCTIONS DE MONTAGE  
**IT** ISTRUZIONI DI MONTAGGIO  
**ES** INSTRUCCIONES DE MONTAJE  
**NL** MONTAGEHANDLEIDING  
**PL** INSTRUKCJA MONTAŻU



**TRILUX**  
SIMPLIFY YOUR LIGHT

## JOVIE LED

SCHEIBE JOVIE 50  
PMMA ERSATZ ...

SCHEIBE JOVIE 70  
PMMA ERSATZ ...

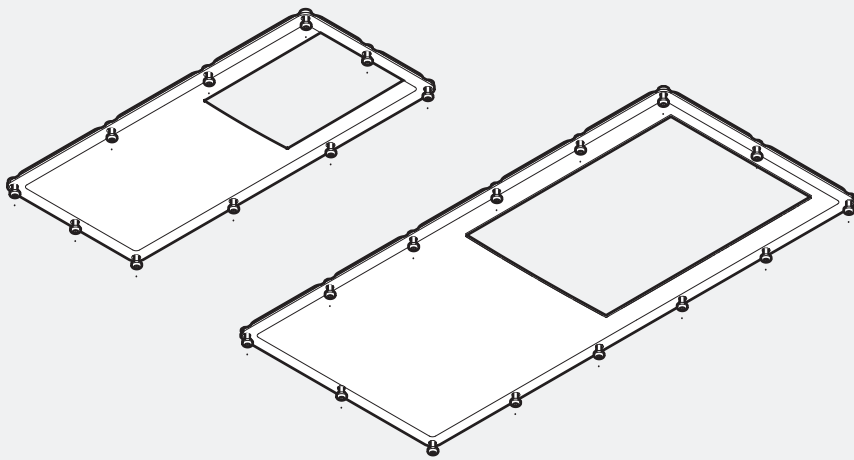

50220271 | 230703



## JOVIE LED

DE

### Zu Ihrer Sicherheit

Lesen Sie sorgfältig alle Hinweise und Montageschritte. Bewahren Sie die Anleitung für Wartungs- oder Demontearbeiten auf.

### Erläuterung der Warnstufen

Beachten und befolgen Sie die Warnhinweise. Nichtbeachten der Warnhinweise kann zu Verletzungen oder Sachschäden führen!



**WARNUNG!** Kennzeichnet Gefahren, die schwere und/oder tödliche Verletzungen zur Folge haben können.



**VORSICHT!** Kennzeichnet Gefahren, die zu Verletzungen oder Gesundheitsgefährdungen führen können.



**WICHTIG.** Kennzeichnet Gefahren, die zu Sachschäden oder Funktionsstörungen führen können.



**TIPP.** Kennzeichnet Informationen, die einen Ratschlag oder nützlichen Hinweis enthalten.

### Erläuterung von Warnhinweisen und anleitenden Piktogrammen



**WARNUNG!** Der elektrische Anschluss muss durch fachkundiges Personal, das ausgebildet und befugt ist, erfolgen.



**WARNUNG!** Die Montage muss durch fachkundiges Personal, das ausgebildet und befugt ist, erfolgen.



**WARNUNG!** Gefahr eines elektrischen Schlages! Arbeiten Sie niemals bei anliegender elektrischer Spannung.



**WICHTIG.** Tragen Sie saubere Montagehandschuhe, um Verschmutzungen vorzubeugen.

### Bestimmungsgemäße Verwendung

Bestimmt als Zubehör für **JOVIE 50 ... ; JOVIE 70 ...**

EN

### For your safety

Read all instructions and mounting steps carefully. Keep the instructions for maintenance or disassembly work.

### Explanation of the warning levels

Observe and follow the warnings. Non-observance of the warnings may lead to injuries or material damage!



**WARNING!** Indicates dangers which can result in serious and/or fatal injuries.



**CAUTION!** Indicates dangers which can result in injuries or health hazards.



**NOTICE.** Indicates dangers which can result in material damage or malfunctions.



**TIP.** Indicates information containing advice or a useful note.

### Explanation of warning messages and instructional pictograms



**WARNING!** The electrical connection must be carried out by professional personnel who are trained and authorised.



**WARNING!** The assembly must be carried out by professional personnel who are trained and authorised.



**WARNING!** Risk of electric shock! Never work with electrical voltage applied.



**NOTICE.** Wear clean installation gloves to prevent soiling.

### Intended use

Intended as accessories for **JOVIE 50 ... ; JOVIE 70 ...**

## JOVIE LED

FR

### Pour votre sécurité

Lisez attentivement toutes les remarques et étapes de montage. Conservez ces instructions pour des travaux d'entretien ou de démontage.

### Explication des niveaux d'avertissement

Respectez et suivez les avertissements. Le non-respect des avertissements peut entraîner des blessures ou des dommages matériels !



**AVERTISSEMENT !** Signale des risques pouvant résulter dans des blessures graves et/ou mortelles.



**ATTENTION !** Signale des risques pouvant entraîner des blessures ou des risques pour la santé.



**IMPORTANT.** Signale des risques pouvant entraîner des dommages matériels ou des dysfonctionnements.



**CONSEIL.** Signale des informations contenant un conseil ou une remarque utile.

### Explication des avertissements et des pictogrammes d'instruction



**AVERTISSEMENT !** Le raccordement électrique doit être effectué par un personnel qualifié, formé et autorisé.



**AVERTISSEMENT !** Le montage doit être effectué par un personnel qualifié, formé et autorisé.



**AVERTISSEMENT !** Risque d'électrocution ! Ne travaillez jamais sous tension électrique.



**IMPORTANT.** Portez toujours des gants de montage propres afin d'éviter des encrassements.

### Utilisation conforme à l'usage prévu

Accessoires destinés à **JOVIE 50 ... ; JOVIE 70 ...**



IT

### Per la propria sicurezza

Leggere con attenzione tutti gli avvisi e le descrizioni delle varie fasi della procedura di montaggio. Conservare le istruzioni per poterle consultare al momento di eseguire lavori di manutenzione e smontaggio.

### Spiegazione dei livelli di avvertenza

Osservare e attenersi alle avvertenze. Una mancata osservanza delle avvertenze può essere causa di lesioni o danni materiali!



**AVVERTENZA!** Mette in guardia dai pericoli che possono comportare lesioni gravi e/o mortali.



**ATTENZIONE!** Mette in guardia da pericoli che possono essere causa di lesioni o rischi per la salute.



**AVVISO.** Mette in guardia da pericoli che possono essere causa di danni materiali o disturbi di funzionamento.



**SUGGERIMENTO.** Indica informazioni comprendenti un consiglio o un avviso utile.

### Spiegazione delle avvertenze e dei pittogrammi didattici



**AVVERTENZA!** Il collegamento elettrico deve essere eseguito da personale competente, addestrato e autorizzato.



**AVVERTENZA!** Il montaggio deve essere eseguito da personale competente, addestrato e autorizzato.



**AVVERTENZA!** Pericolo di scarica elettrica! Mai lavorare in presenza di tensione elettrica.



**AVVISO.** Durante le operazioni di montaggio usare guanti puliti per prevenire l'accumulo di sporco.

### Impiego secondo destinazione

Destinato all'impiego come accessorio per **JOVIE 50 ... ; JOVIE 70 ...**



## JOVIE LED

ES

### Para su seguridad

Por favor, lea detenidamente todas las indicaciones y los pasos de montaje. Guarde las instrucciones para los trabajos de mantenimiento y desmontaje.

### Explicación de los niveles de alerta

Por favor, tenga en cuenta y siga las indicaciones de peligro. ¡El incumplimiento de las indicaciones de peligro puede provocar lesiones o daños materiales!



**¡ADVERTENCIA!** Indica peligros que pueden provocar lesiones graves y/o mortales.



**¡ATENCIÓN!** Indica peligros que pueden provocar lesiones y riesgos de salud.



**¡IMPORTANTE!** Indica peligros que pueden provocar daños materiales o fallos de funcionamiento.



**CONSEJO.** Indica información con un consejo o una pista útil.

### Explicación de las advertencias y los pictogramas de instrucción



**¡ADVERTENCIA!** La conexión eléctrica debe ser realizada por personal profesional, formado y autorizado.



**¡ADVERTENCIA!** El montaje debe ser realizado por personal profesional, formado y autorizado.



**¡ADVERTENCIA!** ¡Riesgo de choque eléctrico! Nunca realice trabajos si esta tiene tensión eléctrica.



**¡IMPORTANTE!** Póngase guantes de montaje limpios para evitar ensuciamiento.

### Uso previsto

Como accesorio para **JOVIE 50 ... ; JOVIE 70 ...**

NL

### Voor uw veiligheid

Lees alle aanwijzingen en montageschappen zorgvuldig. Bewaar de handleiding voor latere onderhouds- of demontagewerkzaamheden.

### Verklaring van de waarschuwningsniveaus

Neem de waarschuwingen in acht en volg de instructies. Bij niet-naleving kan letsel of materiële schade het gevolg zijn!



**WAARSCHUWING!** Wijst op gevaren die zware en/of dodelijke letsels tot gevolg kunnen hebben.



**VOORZICHTIG!** Wijst op gevaren die kunnen leiden tot letsels of gezondheidsrisico's.



**BELANGRIJK.** Wijst op gevaren die kunnen leiden tot materiële schade of functionele storingen.



**TIP.** Wijst op informatie die een advies of een nuttige aanwijzing bevat.

### Verklaring van waarschuwingen en instructiepictogrammen



**WAARSCHUWING!** De elektrische aansluiting moet worden uitgevoerd door bevoegd en opgeleid personeel.



**WAARSCHUWING!** De montage moet worden uitgevoerd door bevoegd en opgeleid personeel.



**WAARSCHUWING!** Gevaar voor een elektrische schok! Werk nooit terwijl deze onder elektrische spanning staat.



**BELANGRIJK.** Draag schone montagehandschoenen, om verontreiniging te voorkomen.

### Bedoeld gebruik

Bedoeld als toebehoren voor **JOVIE 50 ... ; JOVIE 70 ...**

## JOVIE LED

PL

### Zasady bezpieczeństwa

Należy uważnie przeczytać wszystkie instrukcje i czynności montażowe. Zachować instrukcję na wypadek konserwacji lub demontażu.

### Wyjaśnienie poziomów ostrzegania

Przestrzegać wskazówek ostrzegawczych. Nieprzestrzeganie wskazówek ostrzegawczych może spowodować obrażenia ciała lub szkody rzeczowe!



**OSTRZEŻENIE!** Oznacza zagrożenia, które mogą prowadzić do poważnych i/lub śmiertelnych obrażeń ciała.



**UWAGA!** Oznacza zagrożenia, które mogą prowadzić do obrażeń ciała lub zagrożenia dla zdrowia.



**WSKAZÓWKA.** Oznacza zagrożenia, które mogą prowadzić do szkód materialnych lub nieprawidłowego działania.



**PORADA.** Oznacza informacje, które zawierają poradę lub przydatną wskazówkę.

### Objaśnienie ostrzeżeń i piktogramów instruktażowych



**OSTRZEŻENIE!** Podłączenie elektryczne musi być wykonane przez kompetentny personel, który został przeszkolony i posiada odpowiednie uprawnienia.



**OSTRZEŻENIE!** Montaż musi być przeprowadzony przez kompetentny personel, który został przeszkolony i posiada odpowiednie uprawnienia.



**OSTRZEŻENIE!** Niebezpieczeństwo porażenia prądem elektrycznym! Nigdy nie pracować pod napięcie elektryczne.



**WSKAZÓWKA.** Aby zapobiec zabrudzeniom, należy nosić czyste rękawice montażowe.

### Zastosowanie zgodnie z przeznaczeniem

Przeznaczone jako akcesorium do **JOVIE 50 ... ; JOVIE 70 ...**





# JOVIE LED

Type SCHEIBE JOVIE 50  
PMMA ERSATZ ...

~ kg 0,5

Type SCHEIBE JOVIE 70  
PMMA ERSATZ ...

~ kg 0,8

A

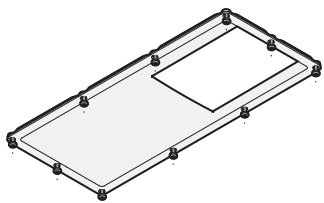
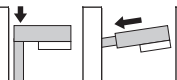

B

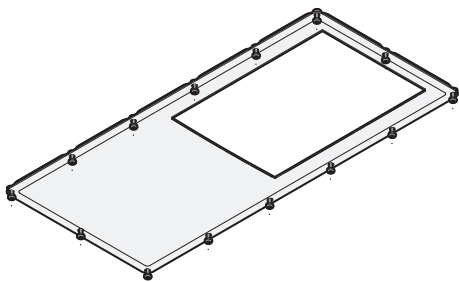
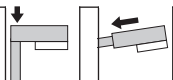

20

# JOVIE LED



01

A

B

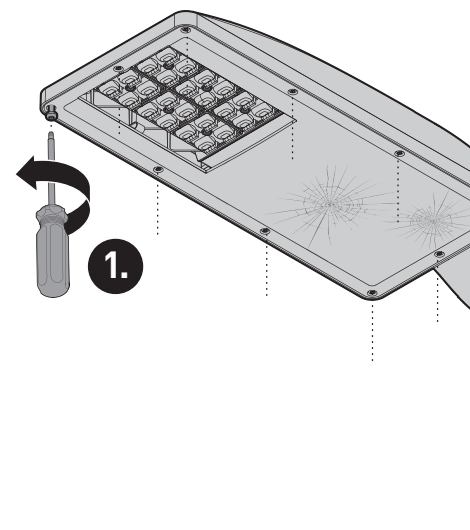

02

A

B

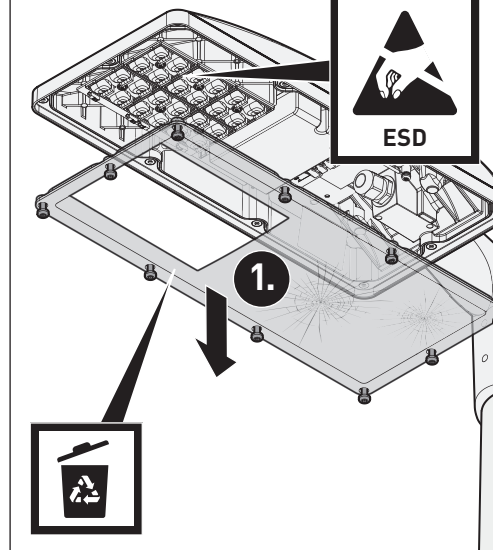

03

A

B

1.

i

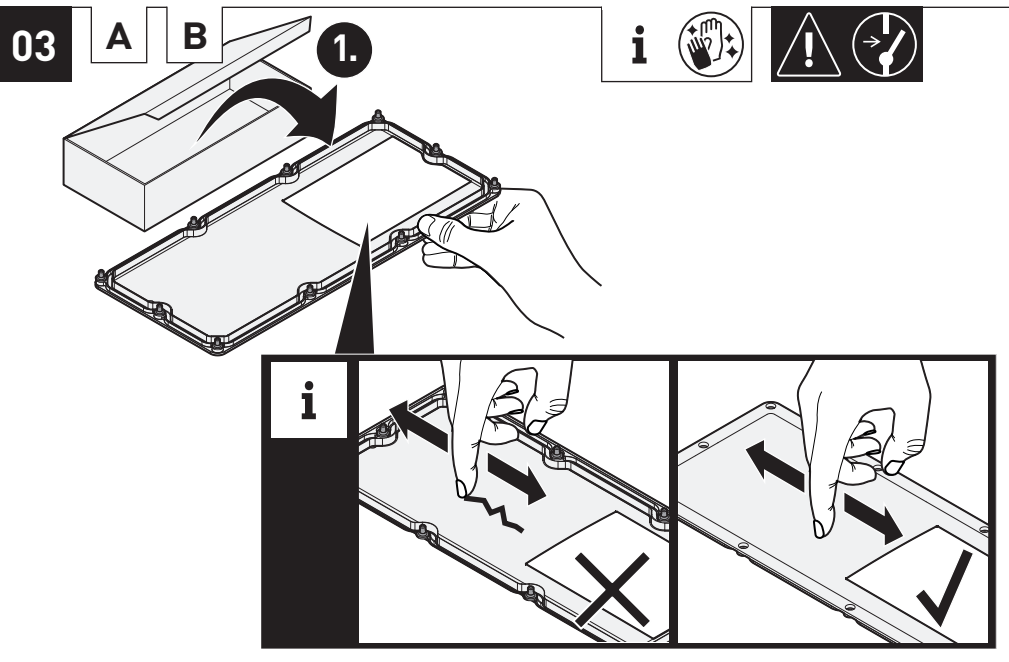



04

A

B

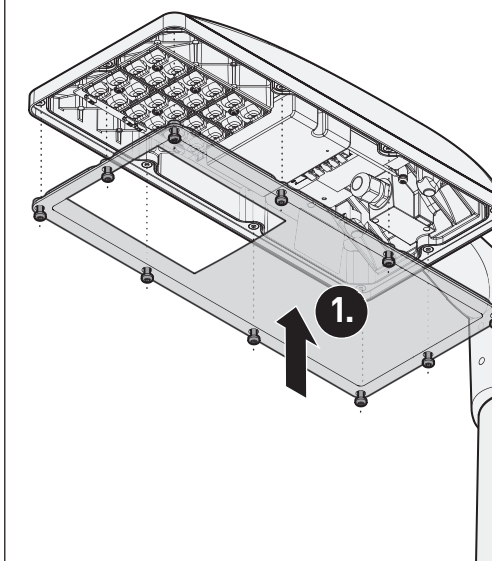

05

A

B

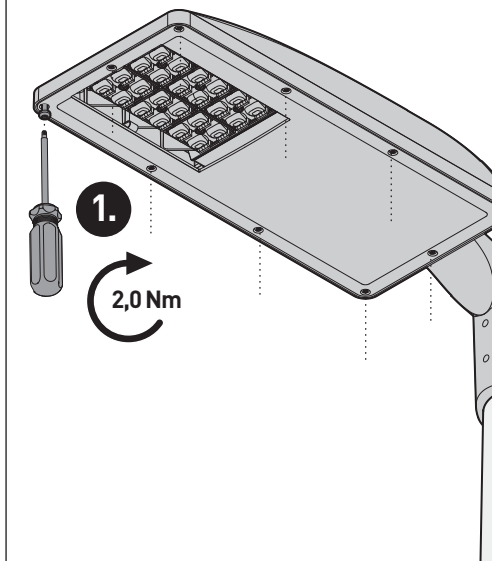

06

A

B

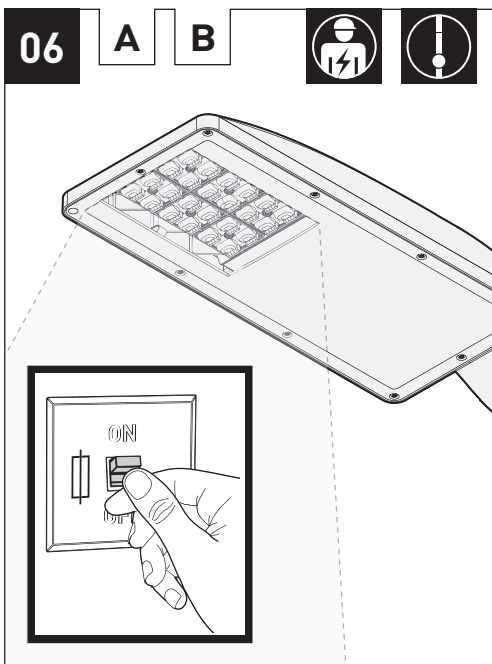

TRILUX GmbH &amp; Co. KG

Heidestraße  
D-59759 Arnsberg  
+49 2932 301-0  
info@trilux.com  
www.trilux.com